

Project Hessdalen

Strange unknown light phenomena started to show up in Hessdalen December 1981. There could be up to 20 observations a week. This period lasted until late 1984. Today there are in the order of 20 observations a year. Project Hessdalen ran a field investigation in 1984 and 1985, and are now running Hessdalen Automatic Measurement Station (AMS). Many pictures and instrumentation readings have been obtained.

Hessdalen

Project Hessdalen received its name from the small valley, that is Hessdalen, 40 km north of the town Røros in Norway. The valley is about 15 km long, facing north-south. There are mountains to the east, Rognefjell in the northern part, Stordalshøgda and in the south lies Ratvollfjellet. These mountains range from 917 m to 995 m above sea level. In the west you'll find the mountains, from the north Finnsåhøgda, Fjellbekkhøgda, Båtjørnhøgda and in the south you find the mountain Røhovda. These mountains range from 1063 to 1088 m above sea level. There are two lakes south in the valley, Hersjøen in the eastern part and Øyungen to the west. Most of the 140 inhabitants live close to the road, about 700 m above sea level.

The phenomena

In December 1981 the inhabitants started to see strange phenomena in the valley, mostly reported as a light. These lights showed up very often, up to 20 observations a week were reported. This high frequency lasted to the summer of 1984. Then the frequency decreased to the order of 20 a year, which remains the frequency today. Most observations were seen in the valley, but the nearby districts also had many observations.

These lights could be anywhere. Sometimes they were reported to be just above the roof of the houses, or just above the ground. Sometimes they could be high up in the air. However, generally

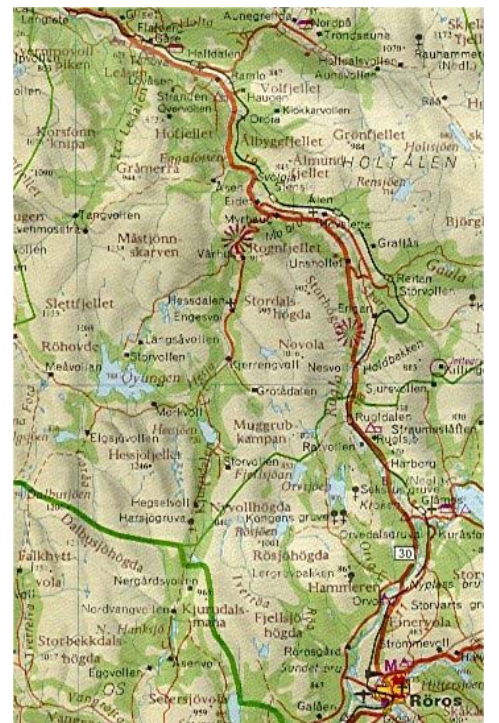

the lights were reported to be below the tops of the mountains nearby. No one could give any explanations of these lights. The colour and the behaviour were different, but the lights could be split in to three main groups:

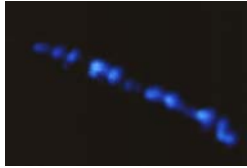

- 1. Small, strong, white or blue flashes, which could show up anywhere in the sky.

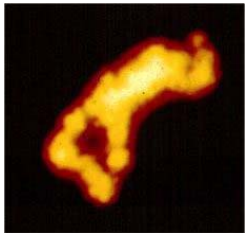

- 2. Yellow lights, or white, with different shapes. Sometimes as a ball, sometimes oval, sometimes “cigar” or other forms. These lights have very often been seen in the valley, just above the roof of the houses, or even close to the ground. They could be stationary for more than an hour, move slowly around in the valley, and sometimes show large accelerations and speeds. They could sometimes be seen higher up in the sky. The direction of movement was mostly in a north-south course.

- 3. Several lights together, with a fixed distance from each other. It looked like the lights emanated from a black object. Mostly it was two yellow or white lights with a red in front. Many



people talked about "The object", when they saw this type of light. These lights could move slowly around the top of the mountains. The direction of the "travelling" was mostly in a north-south course.

The “lights” were mostly seen in the autumn, winter and spring. This may be because Hessdalen is so far north that the dark nights are very long in the wintertime. In the summertime there is daylight nearly the whole night.

Project Hessdalen

Project Hessdalen was born on the 3rd of June 1983. One of the main goals was to find out more about the phenomena in Hessdalen, and to get the mainstream



scientist more involved. A field investigation was run from the 21st of January to the 26th of February 1984. In total 40 people participated. The results are presented in a technical report, which can be found on the Internet at www.hessdalen.org. The summary of these 5 weeks of fieldwork is as follows:

1) In total 53 phenomena were observed.

2) A radar measured the distance and speed of the phenomena. The highest speed recorded was on a light travelling towards the north with a speed of 30.000 km/h. The radar managed to capture the phenomena, when our eyes saw nothing, while it was invisible.

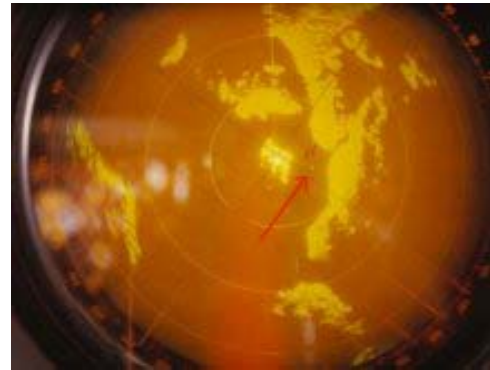

3) The seismograph did not measure any local seismic activity. All recordings taken were from earthquakes occurring in other parts of the world.

4) The magnetograph measures the changes in the magnetic field. There were changes in the magnetic field when the phenomena appeared. There was a pulsation present at 40% of the sightings.

5) The Geiger counter, which measures the nuclear radiation, did not show any change in the counting rate when the phenomena showed up. But this counter lied far away from the phenomena. We know that radiation decreases significantly with distance, so if there had been any change, then the phenomena would have been very dangerous. Even if we did not measure anything, there could have been radiation anyway, but not strong enough for our Geiger counter to pick up.



An unknown light phenomenon in Hessdalen. Photo by Arne P. Thomassen, 25. September 1982

6) The IR-viewer, which looks into the infrared part of the spectrum, was not used, as there was not enough people at the headquarter. The people were busy with the other instruments and the cameras.

- 7) The spectrumalyzer we used measure all the frequencies between 100 KHz and 1200 MHz, and can see if any radio or TV-channels will be disturbed. There was noise sometimes. The noise had harmonics with 80 MHz between each, which covered the whole the band. The level of the amplitude moved up and down every 2 seconds (a frequency of about 0,5 Hz).
- 8) A camera, with a grating in front, will show the distribution of the wavelength of the lights. We managed to get three pictures, which is good enough for an analysis. They show a continuous spectre. A glowing gas will show a spectre with lines in it. That was not the case on our pictures.

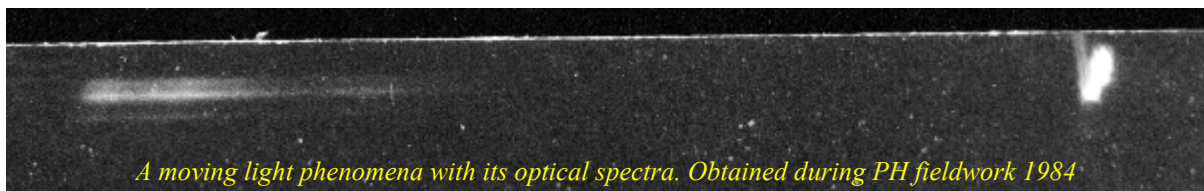

- 9) Maybe the strangest happening was the test with a laser. Before the fieldwork, people told us that the “light” disappeared when a strong spotlight was directed on to the “light”. We wanted to test that. Instead of a spotlight, we used a He-Ne laser.

A regular flashing light was travelling towards the north. When we directed the laser beam on to it, it became a double flashing light. Once we moved the beam away, the light went back to a regular flashing light again. We directed the beam on to it again, and it started this double flashing at once. We did this up and down with the laser beam 4 times while this light was moving towards the north. Every time it doubled its frequency of flashing. The second test was carried out one hour later, when a similar light was travelling towards the south. The same thing happened. Now we moved the laser beam up on to the light and down away from the light 5 times. 4 of those 5 times the frequency doubled.

One week after our test with the laser, a red light move around the feet of the observers, on the ground. It looked just as if a similar laser as ours was used. It lasted only a couple of seconds, and not long enough to find out where it came from. The only place it could have come from was above us in the sky.

Occasionally some of the observers felt a waving movement, just as if they were sitting in a boat in the ocean. Those who felt this described the same direction on the waving, but the frequency was different for each person who felt it. Such feeling may come if the brain is in a strong low-frequency EM-field. There were no instruments that could measure if such an EM-field was present when this feeling came.

The headquarter was located on a hill. The distance to the nearest place we could get 220V power was 600 m. The 600m power cable was lying on the ground. Many times the power failed when the light phenomena was arriving. Just after it disappeared the power came back again. This happened many times, but not every time.

We did discuss the results from the fieldwork with mainstream scientist at different research establishments in Norway. A technical report was written, which can be found on the Internet, at <http://www.hessdalen.org/reports/hpreport84.shtml>



Project Hessdalen headquarter 1985

A new fieldwork was carried out, with instruments, from the 12th to the 28th January 1985. The second part of this fieldwork, between the 29th January and the 11th February, was carried out with no instruments, and only a few observers were present. We wanted to test if there were more observations when no instruments were present. Many people explained that they got an observation just before or just after their camera was not ready for use. As

if “it” did not want to be captured on film. This, and our problems with the power, were the reasons for why we had these two periods. Sadly, we did not observe anything in the first period, and only one good observation in the last period. Only one good observation during those 4 weeks is too little to draw any conclusion on our test. Even if the weather was worse this year, it was obvious that the period with high intensity was over.

The job of telling people that the phenomena are real and to bring more of the mainstream scientists into the field started.

The new Project Hessdalen

The light-phenomena in Hessdalen was still present. Reports were coming in. Not as much as the period from 1981 to 1984, but it was in the order of 20 observations a year. This was considered to be high enough intensity to do something more.

During a presentation of Project Hessdalen for the people in Hessdalen, on the 9th of October 1993, we started a



*20th August 2000 at 9:55 P.M.
A flashing light is moving up the hill*

discussion “on what to do now”. We agreed to arrange a workshop in Hessdalen for the mainstream scientist. From Thursday the 24th to Saturday the 26th March 1994 the “*First international workshop on the unidentified atmospheric light phenomena in Hessdalen*” was run. Twenty seven scientist from 8 different countries participated. The invitation to that workshop was mainly sent to ball lightning scientists. The reason for that was that this field was closest related to the ”light”-phenomena in Hessdalen, and in that field did mainstream scientists carry out research.

The workshop concluded that the phenomena are not ball lightning’ and that more data is needed. The new Project Hessdalen was now located at Østfold College. The students there started to work with an automatic measurement station. This work was carried out as their final thesis. It was a big job, and several student groups worked with it. The station was ready for installation in the summer of 1998.

Hessdalen Automatic Measurement Station

Hessdalen AMS was installed in Hessdalen on the 7th of August 1998. It is located in a ”Blue box” northeast in Hessdalen, in the mountainside of Rognefjell. It is on a block of land owned by Bjarne and Hallfrid Lillevold. The camera is looking towards west so that the mountain Finnsåhøgda can be seen.



Hessdalen AMS, system 1, consists of two computers, one black-and-white CCD-camera, one video recorder and one magnetometer. The camera is connected to one computer and to a video recorder. The computer analyses the picture from the CCD-camera every second. If a light suddenly arrives in the picture, an alarm will be generated, and the alarm picture is saved. The alarm will start the video recorder and send the alarm picture directly on to the Internet. Everyone with Internet access can see the alarm picture just after it was taken.

The light must move fast enough, be big enough, and strong enough to trigger the alarm. That means that not all unknown light phenomena are captured. It is possible to adjust at these levels in the computer, but if we set it too low, the amount of false alarms will

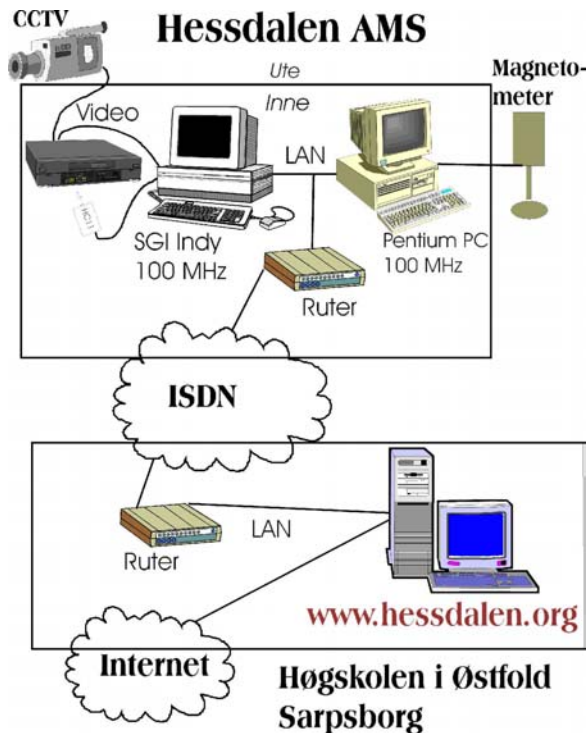

be too high. To find out if the alarm picture is an interesting picture, which might show the unknown light, the alarm picture must be studied. If it is interesting, the picture is saved at the folder “interesting picture”, and will be studied further when the video arrives at Østfold College.

Hessdalen AMS also takes a picture and measures the magnetical field every hour, which is then send to the Internet.

Interesting pictures

During the period from August 1998 to August 2001, there were 271 interesting pictures. 148 of these have been studied closely. There are 79 pictures showing an unknown light, out of these 148 pictures. All of them can be found on the Internet (www.hessdalen.org)

	1998	1999	2000	2001	1998-2001	
	total	total	total	total		
January		22	8	16		
February		11	6	3		
March		5	5	11		
April		2	0	9		
May		4	3	1		
June		1	1	1		
July		0	0	0		
August	3	5	11	5		
September	8	3	20			
October	7	4	10			
November	10	7	8			
December	18	23	20			
Total interesting pictures:	46	87	92	46	Sum	271
Total analyzed:	24	40	64	20	Sum	148
Unidentified:	18	20	34	7	Sum:	79
Explained:	6	20	30	13	Sum:	69
	1998	1999	2000	2001		

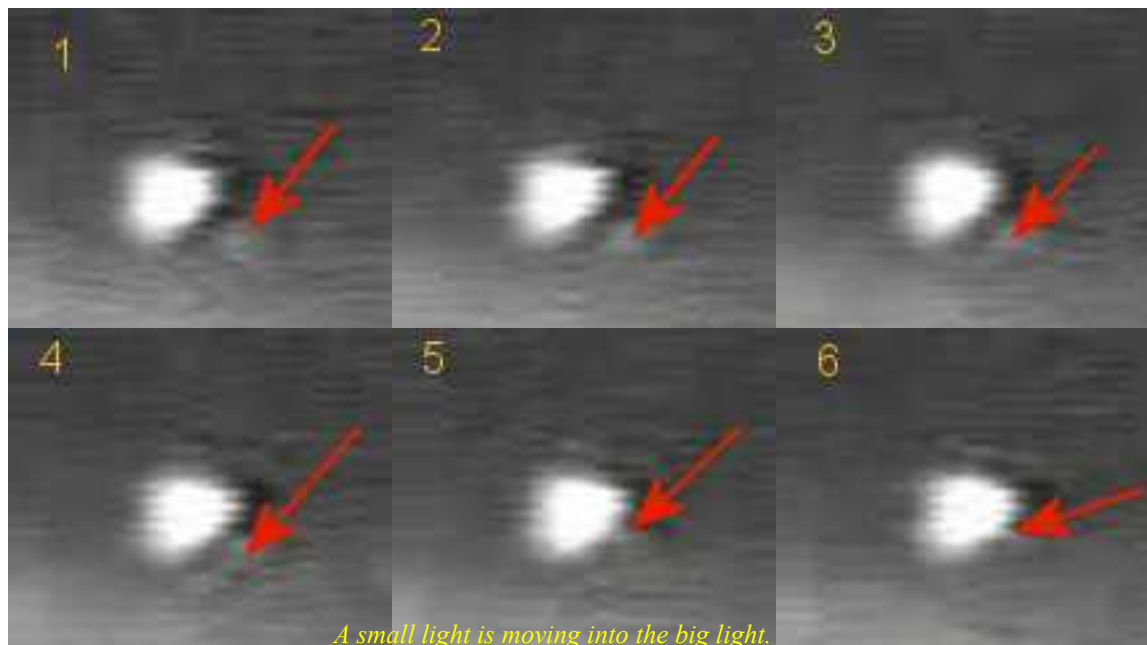

This interesting picture from the 4th of December 1999, which was also captured on the video, shows a light moving towards the north. Suddenly, you can see a small light, just beneath the main light, moving into the big light.

Hessdalen AMS, system 2.

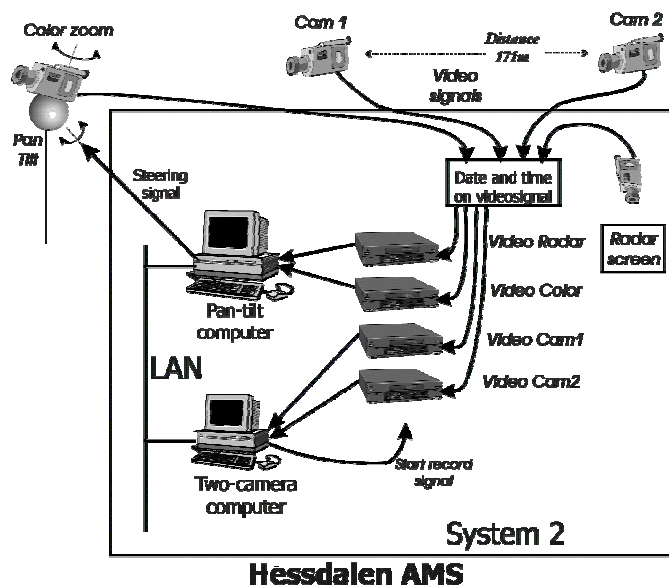

With only one camera, it is impossible to calculate the distance to the light. By using two cameras, it is possible to calculate the distance. System 2 has two colour cameras, which are located 171m apart. System 2 has also a zoom camera, mounted on to a pan-tilt unit, and a camera watching the radar screen. When both Cam1 and Cam2 detect a light, the direction is calculated, which is sent to the pan-tilt computer, so that it can move the zoom camera in the correct direction. When the light moves, the pan-tilt unit will follow its movement, and all is recorded on to the video. Alarm pictures,

with the calculated distance to the light, are sent to the Internet. Pictures from the zoom camera are also sent to the Internet at www.hessdalen.org. System 2 was installed in the summer of 2001. It will be finished in the summer of 2002.

Late November 2001, there was an 'egg' installed in the station (for the Global Consciousness Project at PEAR Lab).

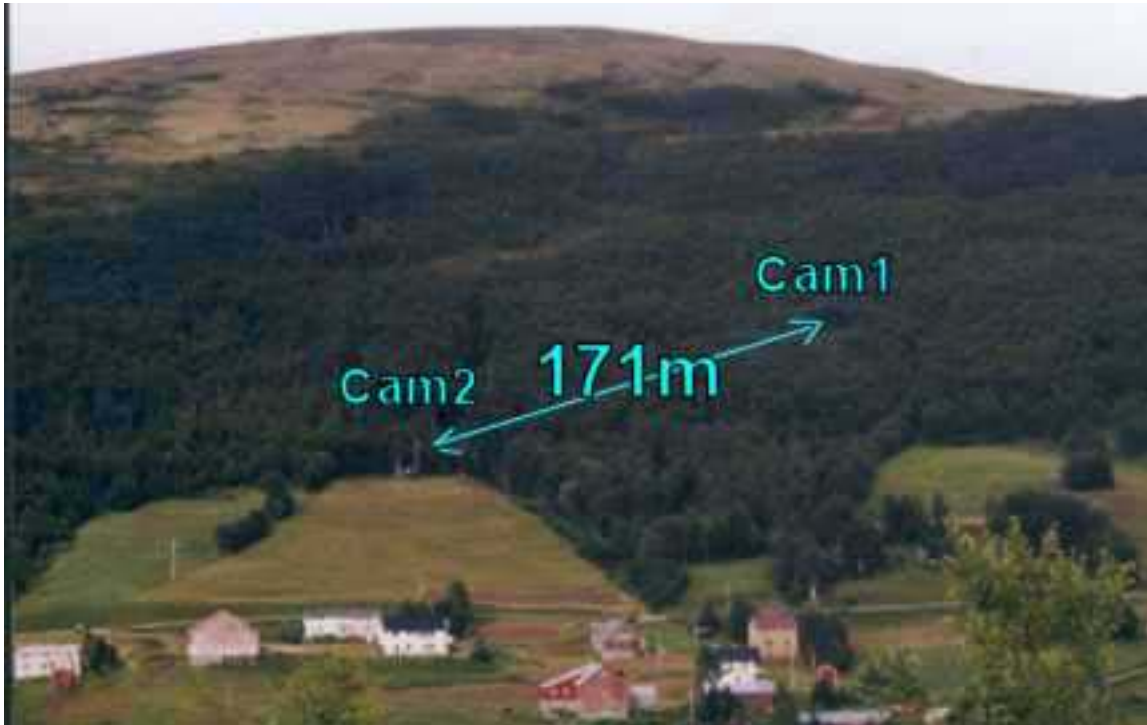

Italian researchers

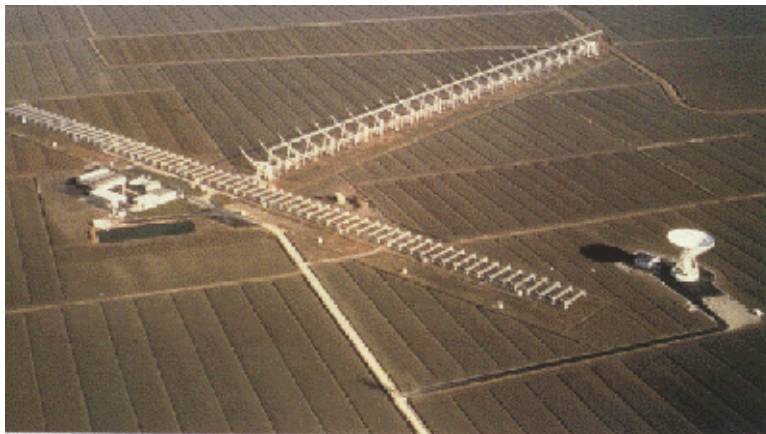

Director, Dr. Stelio Montebugnoli at the CNR Institute for Radio Astronomy (IRA) in Bologna, Italy, and some of his staff, together with Dr. Massimo Teodorani, carried out one-month field investigations in Hessdalen, both in the summer of 2000 and 2001. They did measurements in the VLF and ULF part of the spectrum, and also at 1.4

GHZ. Among their results, you find Doppler measurements. In the band from 300 Hz to 10.000 Hz, you could sometimes see a Doppler signal, which varied in speed. At its fastest the signal was 1/3 of the speed of light.

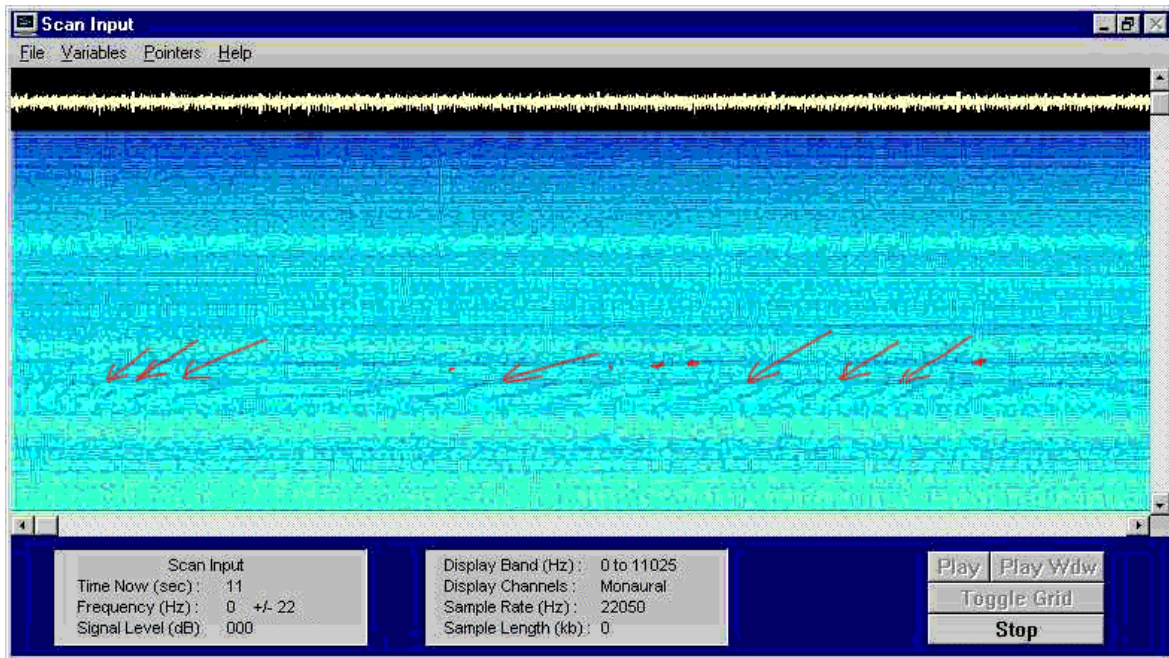

A doppler signal is measured in the ULF band

We want to put more cameras up, so that more areas of the valley can be covered. We also want to put other type of sensors up so we can get the data, which can give us the answers we seek.

A similar station should be put up on other locations around the world, with similar activity.

*April 2002,
Erling P. Strand
Østfold University College,
P.O.Box 1192, Valaskjold,
NO-1705 Sarpsborg,
Norway*

*E-mail: Erling.P.Strand@hiof.no , and epstrand@online.no
Phone work: +47-69104032, Mobile phone: +47-41425411, Phone home: +47-69169600
Fax work: +47-69104002, Fax home: +47-69168018*



A view through one of the two camera's of Hessdalen AMS, system 2. In the background you see mount Finnsåhøgda. In front of that mountain, you can see the hill Vårhuskjølen.